



# Aetos™ 5-R Series eSWIR Camera Core

## Preliminary Data Sheet



The Aetos™ 5-R Series camera cores include the Aetos™ VGA5-R (640x512) and Aetos™ HD5-R (1280x1024), featuring the industry's smallest eSWIR sensors made to enable the smallest of cryocooled infrared imaging systems. The Aetos™ captures snapshot eSWIR imagery using Attollo Engineering's HOT Type-II Superlattice (T2SL) detector material. The extremely small pixel pitch of 5  $\mu\text{m}$  enables more pixels on target with a short focal length optic, reducing overall sensor size. The camera core uses a rotary cooler for fast cooldown and high power efficiency. The eSWIR sensors are also capable of supporting broadband imaging along with day and night laser see-spot capabilities. The camera cores are built for low SWaP applications and offer a significant opportunity for cost savings at the system level compared to competing eSWIR cameras. With a volume of 134  $\text{cm}^3$  and weight of 221 grams, these rotary cooled cameras are ideal for small gimbal integration as well as use in SWaP-constrained handheld and soldier-carried systems.

### Highlights

- Technology: HOT T2SL eSWIR provides imagery with smaller cooler 0.9–2.4  $\mu\text{m}$  wavelength band
- Small pitch: 640 x 512, 5  $\mu\text{m}$  and 1280 x 1024, 5  $\mu\text{m}$  pixel pitch reduces the lens size
- Small: 4.2 x 4.6 x 8.6 cm and 221 grams
- Fast cooldown: 2.5 minutes to operating temp
- Low power consumption: < 10 W cooldown and < 4.5 W with room temperature ambient
- Easy to talk to: Multiple output interfaces including USB-C, MIPI, and Camera Link
- Export friendly: has US Commerce classification as EAR 6A003.b.4.a

### Applications

- Small gimbals and SUAS
- Soldier Borne and handheld systems
- Long range imaging through environmental obscurants
- Security and surveillance
- Hyperspectral imaging
- Machine vision
- Precision agriculture
- Covert illuminated imaging and laser see-spot
- Laser designator and imaging and decode\*  
\*with separate Attollo laser event detector module

The Aetos™ 5-R eSWIR camera cores are designed and manufactured in Attollo's 44,000  $\text{ft}^2$  facility in Camarillo, California. Attollo Engineering specializes in sensors that combine infrared and laser imaging as well as standard and custom IDCA designs for your applications. Attollo is a merchant supplier of standard and custom format III-V detector arrays, hybridized focal plane arrays, and camera assemblies. Attollo Engineering is AS9100 certified.

## SYSTEM FEATURES

Aetos™ 5-R Series:	Aetos™ VGA5-R	Aetos™ HD5-R
<b>Top Level</b>		
Sensor Type	eSWIR T2SL	
Sensor Size	640 x 512, 5 μm	1280 x 1024, 5 μm
Spectral Band	0.9—2.4 μm (Standard)	
Frame Rate Options	Typical: 30 Hz Max: 220 Hz	Typical: 30 Hz Max: 60 Hz (HD720p)
Time to Image	< 2.5 min	

<b>Mechanical</b>	
Size (L x W x H)	8.6 cm x 4.2 cm x 4.6 cm
f/#	f/2.5, f/1.8, f/1.4, f/1.2
Cold Aperture Height	9.5 mm from FPA
Weight	< 221 grams

<b>FPA Characteristics</b>	
Shutter Mode	Snapshot
Well Capacity	$3.0 \times 10^5$ electrons
Read Noise	80 electrons
Quantum Efficiency	> 65% (1.2—2.3 μm)
Readout Mode	Integrate then read
Integration Time	0.1 μsec — frame time less 4.5 msec
Max Frame Rate	220 Hz full frame 60 Hz
Windowing Capable	Yes, max frame rate increases as a function of row reduction
External Sync	Sync In and Sync Out
Operability	> 99.5%

<b>Video Interface</b>	
Parallel (16 bit)	Included
USB-C	With personality board
MIPI	With personality board
Camera Link	With personality board
Image Processing	Windowing, NUC, BPR, AEC, AGC, Averaging, Histogram Equalization

<b>Interfacing</b>	
Parallel	50 pin Hirose DF40-50
Input Voltage	Camera: 5V±10%; Cooler: 12V±10%
Power Dissipation	< 10 W cooldown, < 4.5 W steady state (23°C)
Communication	USB (USB-C or Camera Link)
SDK and GUI Available	Yes

<b>Cooler Reliability</b>	
Cooler MTTF	>10,000 hours

<b>Environmental</b>	
Operating Temperature	-40°C to +71°C*
Storage Temperature	-50°C to +85°C
Max Altitude	40,000 feet
Humidity	5-95% relative humidity (non-condensing)

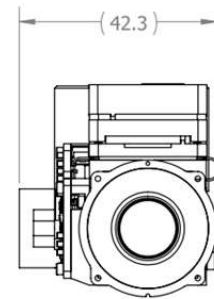
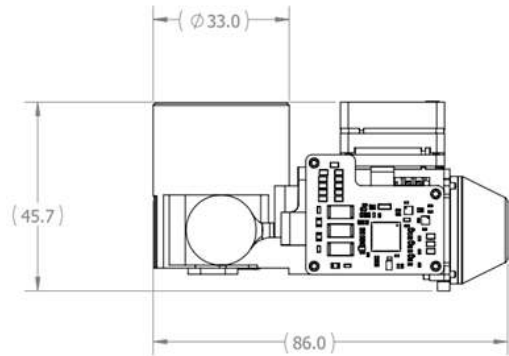

Equipment described herein is subject to US export regulations under EAR and may require a license prior to export under ECCN 6A003.b.4.a. Specifications are subject to change without notice. © 2025 Attollo Engineering LLC. All rights reserved. XM000036 REV.2025.09.26

### Preliminary Data Sheet

