



Griffin™ 5-R Series MWIR Camera Core

VGA5-R and HD5-R MWIR Camera Cores with Low System SWaP-C



The Griffin™ 5-R Series camera cores include the Griffin™ VGA5-R (640x512) and Griffin™ HD5-R (1280x1024), featuring the industry's smallest MWIR sensors made to enable the smallest of cryocooled infrared imaging systems. The Griffin™ 5-R Series captures snapshot MWIR imagery using Attollo Engineering's HOT Type-II Superlattice (T2SL) detector material. The extremely small pixel pitch of 5 μm enables more pixels on target with a short focal length optic, reducing overall sensor size. The Griffin™ 5-R series uses a rotary cooler for fast cooldown and high power efficiency. The Griffin™ VGA5-R and Griffin™ HD5-R sensors are also capable of supporting broadband imaging along with day and night laser see-spot capabilities. The Griffin™ 5-R series MWIR Cores are built for low SWaP applications and offers a significant opportunity for cost savings at the system level compared to competing MWIR cameras. With a volume of 134 cm^3 and weight of 221 grams, these rotary cooled cameras are ideal for small gimbal integration as well as use in SWaP-constrained handheld and soldier-carried systems.

Highlights

- Technology: HOT T2SL MWIR provides imagery with smaller cooler 3.2–5.0 μm (MW) and 0.9–5.0 μm (SW/MW) wavelength bands. Shorter wavelengths and CO₂ notch cold filter available
- Small pitch: 640 x 512, 5 μm and 1280 x 1024, 5 μm pixel pitch reduces the lens size
- Small: 4.2 x 4.6 x 8.6 cm and 221 grams
- Fast cooldown: 2.5 minutes to operating temp
- Low power consumption: 10 W cooldown and 4.5 W typical with room temperature ambient
- Easy to talk to: Multiple output interfaces including USB-C, MIPI, and Camera Link
- Export friendly: has US Commerce classification as EAR 6A003.b.4.a

Applications

- Thermal imaging
- Soldier Borne and handheld systems
- Security & surveillance
- Small gimbals and SUAS
- Laser See-Spot
- Precision agriculture
- Gas leak detection
- Microscopy
- Medical– tissue analysis
- Structural non-destructive fatigue assessment

The Griffin™ VGA5-R and Griffin™ HD5-R camera cores are designed and manufactured in Attollo's 34,000 ft^2 facility in Camarillo, California. Attollo Engineering specializes in sensors that combine infrared and laser imaging as well as standard and custom IDCA designs for your applications. Attollo is a merchant supplier of standard and custom format III-V detector arrays, hybridized focal plane arrays, and camera assemblies. Attollo Engineering is AS9100 certified.

SYSTEM FEATURES

Griffin™ 5-R Series:

Griffin™ VGA5-R

Griffin™ HD5-R

Top Level

Sensor Type	HOT MWIR T2SL	
Sensor Size	640 x 512, 5 μ m	1280 x 1024, 5 μ m
Spectral Band	3.0—5.0 μ m (Standard)* 0.9—5.0 μ m (Broadband)* *Subject to change based on operating temperature and manufacturing tolerances	
NETD	< 30 mK (50% well fill at T _{bb} = 20°C)	
Frame Rate Options	Typical: 30Hz Max: >200Hz	Typical: 30Hz Max: 60Hz
Time to Image	< 2.5 min	

Mechanical

Size (L x W x H)	8.6 cm x 4.2 cm x 4.6 cm	
f/#	f/1.2, f/1.4, f/1.8	
Cold Aperture Height	9.5 mm, 12 mm	
Weight	< 221 grams	

FPA Characteristics

Shutter Mode	Snapshot	
Well Capacity	2.6 x 10 ⁶ electrons (effective)	
Quantum Efficiency	> 50%	
Readout Mode	Integrate then read	
Integration Time	0.1 μ sec	
Windowing Capable	Yes, max frame rate increases as a function of row reduction	
External Sync	Sync In and Sync Out	
Operability	> 99.5%	

Video Interface

Parallel (16 bit)	Included	
USB-C	With personality board	
MIPI	With personality board	
Camera Link	With personality board	
Image Processing	AEC, AGC, averaging, histogram equalization	

Interfacing

Parallel	50 pin Hirose DF40-50
Input Voltage	Camera: 5V \pm 10%; Cooler: 12V \pm 10%
Power Dissipation	10 W cooldown, 4.5 W steady state (23°C), typical
Communication	USB (USB-C or Camera Link) UART, SPI or I2C (Parallel)
SDK and GUI Available	Yes

Cooler Reliability

Cooler MTTF	>10,000 hours
-------------	---------------

Environmental

Operating Temperature	-40°C to +71°C*
Storage Temperature	-50°C to +85°C
Max Altitude	40,000 feet
Humidity	5-95% relative humidity (non-condensing)

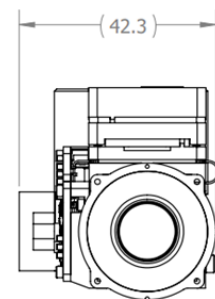
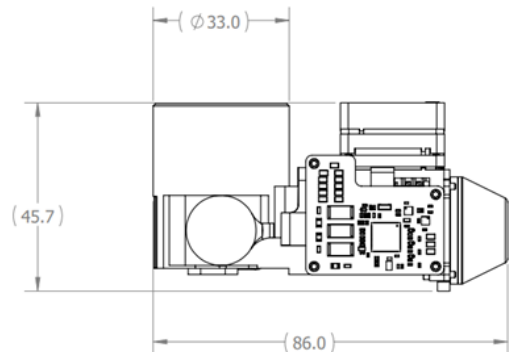

See More



Equipment described herein is subject to US export regulation under EAR and may require a license prior to export under ECCN 6A003.b.4.a. Specifications are subject to change without notice. © 2025 Attollo Engineering LLC. All rights reserved. XM0000030 REV.2025.1.15