



Aetos™ 5-R Series eSWIR Camera Core

Preliminary Data Sheet



The Aetos™ 5-R Series camera cores include the Aetos™ VGA5-R (640x512) and Aetos™ HD5-R (1280x1024), featuring the industry's smallest eSWIR sensors made to enable the smallest of cryocooled infrared imaging systems. The Aetos™ captures snapshot eSWIR imagery using Attollo Engineering's HOT Type-II Superlattice (T2SL) detector material. The extremely small pixel pitch of 5 μm enables more pixels on target with a short focal length optic, reducing overall sensor size. The camera core uses a rotary cooler for fast cooldown and high power efficiency. The eSWIR sensors are also capable of supporting broadband imaging along with day and night laser see-spot capabilities. The camera cores are built for low SWaP applications and offer a significant opportunity for cost savings at the system level compared to competing eSWIR cameras. With a volume of 134 cm^3 and weight of 221 grams, these rotary cooled cameras are ideal for small gimbal integration as well as use in SWaP-constrained handheld and soldier-carried systems.

Highlights

- Technology: HOT T2SL eSWIR provides imagery with smaller cooler 0.9–2.4 μm wavelength band
- Small pitch: 640 x 512, 5 μm and 1280 x 1024, 5 μm pixel pitch reduces the lens size
- Small: 4.2 x 4.6 x 8.6 cm and 221 grams
- Fast cooldown: 2.5 minutes to operating temp
- Low power consumption: < 10 W cooldown and < 4.5 W with room temperature ambient
- Easy to talk to: Multiple output interfaces including USB3 and Camera Link
- Export friendly: has US Commerce classification as EAR 6A003.b.4.a

Applications

- Small gimbals and SUAS
- Soldier Borne and handheld systems
- Long range imaging through environmental obscurants
- Security and surveillance
- Hyperspectral imaging
- Machine vision
- Precision agriculture
- Covert illuminated imaging and laser see-spot
- Laser designator and imaging and decode*
*with separate Attollo laser event detector module

SYSTEM FEATURES

Aetos™ 5-R Series:	Aetos™ VGA5-R	Aetos™ HD5-R
Top Level		
Sensor Type	eSWIR T2SL	
Sensor Size	640 x 512, 5 μm	1280 x 1024, 5 μm
Spectral Band	0.9—2.4 μm (Standard)	
Frame Rate Options	Typical: 30 Hz Max: 220 Hz	Typical: 30 Hz Max: 60 Hz (HD720p)
Time to Image	< 2.5 min	

Mechanical

Size (L x W x H)	8.6 cm x 4.2 cm x 4.6 cm	
f/#	f/2.5, f/1.8, f/1.4, f/1.2	
Cold Aperture Height	9.5 mm from FPA	
Weight	< 221 grams	

FPA Characteristics

Shutter Mode	Snapshot	
Well Capacity	3.0×10^5 electrons	
Read Noise	80 electrons	
Quantum Efficiency	> 65% (1.2—2.3 μm)	
Readout Mode	Integrate then read	
Integration Time	0.1 μsec — frame time less 4.5 msec	0.1 μsec — frame time less 20.1 msec
Max Frame Rate	220 Hz full frame	60 Hz (HD720p)
Windowing Capable	Yes, max frame rate increases as a function of row reduction	
External Sync	Sync In and Sync Out	
Operability	> 99.5%	

Video Interface

Parallel (16 bit)	Included	
UCS-C	With personality board	
Camera Link	With personality board	
Image Processing	AEC, AGC, averaging, histogram equalization, unsharp	

Interfacing

Parallel	50 pin Hirose DF40-50
Input Voltage	Camera: 5V±10%; Cooler: 12V±10%
Power Dissipation	< 10 W cooldown, < 4.5 W steady state (23°C)
Communication	USB (USB-C or Camera Link) UART, SPI or I2C (Parallel)
SDK and GUI Available	Yes

Cooler Reliability

Cooler MTTF	>10,000 hours
-------------	---------------

Environmental

Operating Temperature	-40°C to +71°C*
	*In accordance with thermal considerations described in the mechanical ICD
Storage Temperature	-50°C to +85°C
Max Altitude	40,000 feet
Humidity	5-95% relative humidity (non-condensing)

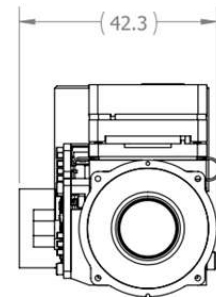
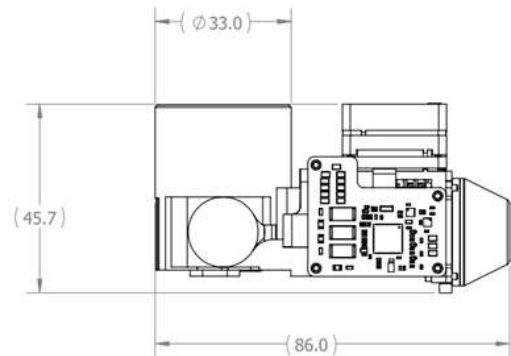

Preliminary Data Sheet



Equipment described herein is subject to US export regulations under EAR and may require a license prior to export under ECCN 6A003.b.4.a. Specifications are subject to change without notice. © 2023 Attollo Engineering LLC. All rights reserved. XM000036 REV.2023.09.25